



G105 vs S135 Drill Pipe Selection Map

API 5DP grade selection for well load, torque, fatigue and inspection review



LOAD



TORQUE



FATIGUE



INSPECTION

G105 Drill Pipe



- 1** 105 ksi minimum yield strength
- 2** Medium-to-deep wells
- 3** Directional wells
- 4** Controlled high-load drilling
- 5** Balanced strength and availability
- 6** Review fatigue and connection records



Selection depends on well load, torque, fatigue, connection and inspection records.



S135 Drill Pipe



- 1** 135 ksi minimum yield strength
- 2** Deep and ultra-deep wells
- 3** Extended-reach drilling
- 4** High torque and high hook load
- 5** Higher tensile margin
- 6** Review hardness, H₂S risk and tool joint condition



H₂S or sour-service exposure requires additional material and hardness review.

TYPICAL GRADE PROPERTIES (API 5DP)

Grade	Minimum Yield Strength (ksi)	Minimum Tensile Strength (ksi)
G105	105	125
S135	135	155

KEY CONSIDERATIONS

- Well depth and profile
- Hook load and torque demands
- Fatigue life (bending, tension, side load)
- Connection performance and makeup
- Inspection history and condition



Follow API Spec 5DP, company standards, and jurisdictional requirements.



TECHNICAL NOTE

This map provides general guidance. Engineer judgment and field data prevail.



G105 vs S135 Drill Pipe Mechanical Strength and Service Window

API 5DP strength position, typical drilling demand and practical review points



LOAD



TORQUE



FATIGUE



INSPECTION

Mechanical Strength Comparison

Grade	Minimum Yield Strength	Maximum Yield Strength	Minimum Tensile Strength
G105	105,000 psi / 724 MPa	135,000 psi / 931 MPa	115,000 psi / 793 MPa
S135	135,000 psi / 931 MPa	165,000 psi / 1138 MPa	145,000 psi / 1000 MPa

Strength Position

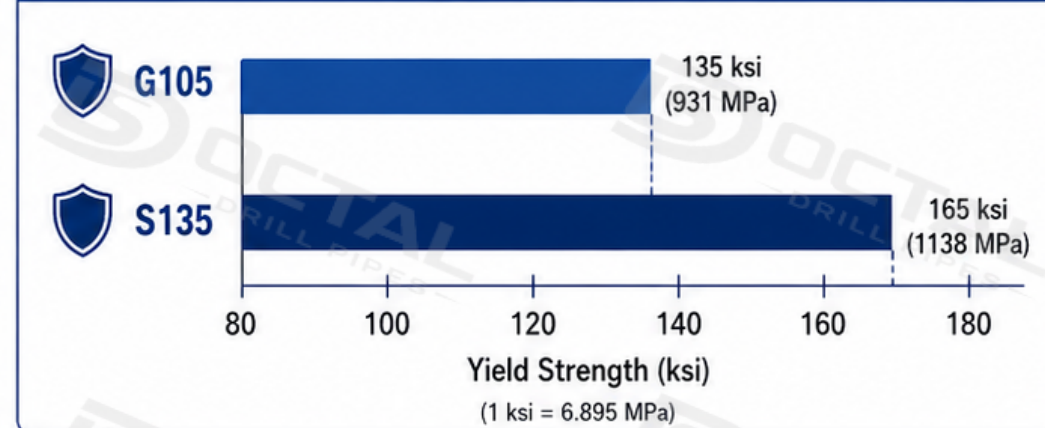

Typical Application Window

Application	G105 (105 ksi Grade)	S135 (135 ksi Grade)	Review Guidance
Medium-to-deep wells	✓ Commonly reviewed	—	🔍 Standard loads deeper sections
Directional wells	✓ Review commonly	✓ May be used	⚙️ Use either based on torque and fatigue
Extended-reach drilling	—	✓ More strongly reviewed	📊 Higher fatigue and bending demands
High-torque drilling	—	✓ More strongly reviewed	🔄 High torque and connection loads

Selection Notes

	Higher strength is not the only selection factor
	Torque, fatigue and connection control matter
	Tool joint condition affects field acceptance
	H ₂ S exposure requires additional review
	MTC and inspection records must be traceable



TECHNICAL REMINDER

A stronger grade does not replace connection matching, fatigue control or document verification.



G105 vs S135 Drill Pipe Inspection and Review Checklist

Connection control, sour-service review and traceable shipment documents



LOAD



TORQUE



FATIGUE



INSPECTION

1) DRILL PIPE JOINT – KEY AREAS FOR INSPECTION

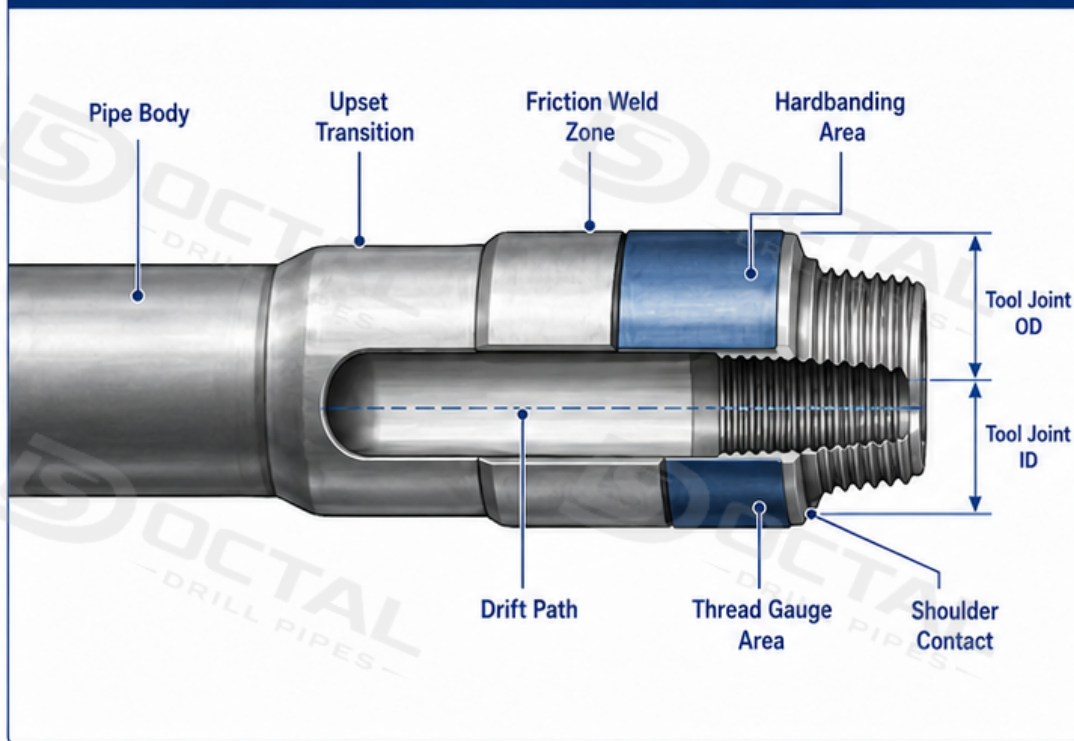

2) CONNECTION AND INSPECTION CHECKS

	Connection type	Match NC / IF / FH / premium connection to the existing string
	Tool joint OD / ID	Confirm handling compatibility and hydraulic clearance
	Make-up torque	Review against connection design and field practice
	Thread gauge record	Confirm thread form and shoulder condition
	Drift test	Verify internal clearance
	Hardness record	Review especially for higher-strength or sour-service conditions

3) RECOMMENDED DOCUMENT CHAIN



4) SHIPMENT REVIEW CHECKLIST

<p>1 </p> <p>Grade and size match RFQ</p> <input type="checkbox"/>	<p>2 </p> <p>Heat number matches MTC</p> <input type="checkbox"/>	<p>3 </p> <p>Mechanical properties verified</p> <input type="checkbox"/>	<p>4 </p> <p>Tool joint dimensions confirmed</p> <input type="checkbox"/>	<p>5 </p> <p>NDT completed per ITP</p> <input type="checkbox"/>	<p>6 </p> <p>Thread inspection accepted</p> <input type="checkbox"/>	<p>7 </p> <p>Packing list matches pipe count</p> <input type="checkbox"/>	<p>8 </p> <p>Third-party inspection added when required</p> <input type="checkbox"/>
--	---	--	---	---	--	---	--



H₂S or sour-service exposure requires additional material, hardness and environmental review.